

### Specifications

Nominal Voltage	12V	
Rated capacity (20 hour rate)	9Ah	
Dimensions	Length	151±1.5mm(5.94inch)
	Width	65±1mm(2.56inch)
	Height	94±1mm(3.70inch)
	Total Height	100±1mm(3.94inch)
Approx. Weight	2.65kg(5.84lbs)±4%	

### Outer dimensions (mm)

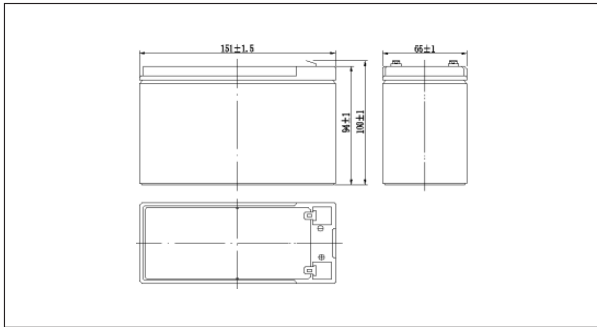

### Terminal Type (mm)

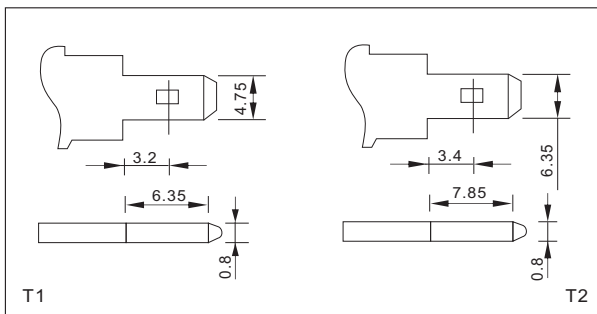

### Characteristics

Capacity (25°C)	20HR(10.5V)	9Ah
	10HR(10.5V)	8.4Ah
	1HR(9.60V)	5.4Ah
Terminal type		T1/T2
Internal resistance (Fully charged,25°C)		Approx. 19m Ω
Capacity affected by temperature (20HR)	40°C	102%
	25°C	100%
	0°C	85%
	-15°C	65%
Self-discharge (25°C)	3 months	Remaining Capacity:91%
	6 months	Remaining Capacity:82%
	12 months	Remaining Capacity:65%
Nominal operating temperature		25°C ±3°C(77°F ±5°F)
Operating temperature range	Discharge	-15°C~50°C(5°F~122°F)
	Charge	-10°C~50°C(14°F~122°F)
	Storage	-20°C~50°C(-4°F~122°F)
Float charging voltage(25°C)		13.50 to 13.80V Temperature compensation: -18mV/°C
Cyclic charging voltage(25°C)		14.50 to 15.00V Temperature compensation: -30mV/°C
Maximum charging current		2.7A
Maximum discharge current		135A(5 sec.)
Designed floating life(20°C)		5 years

### Construction

Component	Positive plate	Negative plate	Container	Cover	Separator	Electrolyte	Safety valve	Terminal
Raw material	Lead dioxide	Lead	ABS	ABS	AGM	Sulfuric acid	Rubber	Copper

### Constant Current Discharge Characteristics Unit:A(25°C,77°F)

F.V/Time	5min	10min	15min	30min	60min	2h	3h	4h	5h	10h	20h
9.60V	34.4	21.8	17.0	9.59	5.90	3.22	2.23	1.85	1.57	0.85	0.46
9.90V	33.3	21.1	16.6	9.39	5.81	3.21	2.22	1.83	1.56	0.85	0.45
10.2V	32.0	20.3	16.0	9.11	5.66	3.18	2.20	1.82	1.55	0.84	0.45
10.5V	30.6	19.4	15.4	8.89	5.55	3.13	2.19	1.81	1.54	0.84	0.45
10.8V	28.9	18.3	14.6	8.56	5.38	3.05	2.12	1.75	1.49	0.82	0.44

### Constant Power Discharge Characteristics Unit:W(25°C,77°F)

F.V/Time	5min	10min	15min	30min	60min	2h	3h	4h	5h	10h	20h
9.60V	384	246	194	110	68.3	37.7	26.5	22.0	18.7	10.2	5.48
9.90V	372	238	189	108	67.2	37.5	26.3	21.8	18.6	10.2	5.46
10.2V	357	228	182	104	65.5	37.2	26.2	21.7	18.5	10.1	5.43
10.5V	341	219	176	102	64.2	36.6	26.0	21.5	18.4	10.1	5.40
10.8V	322	206	167	98.1	62.3	35.7	25.2	20.9	17.8	9.87	5.29

Note: The above characteristics data can be obtained within three charge or discharge cycles.

● Discharge characteristics(25°C)

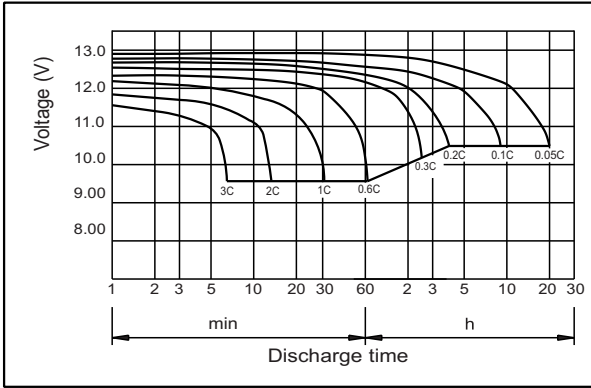

● Charging characteristics (25°C)

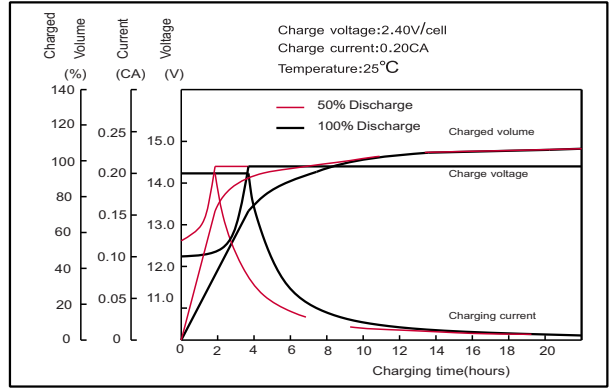

● Effect of temperature on capacity

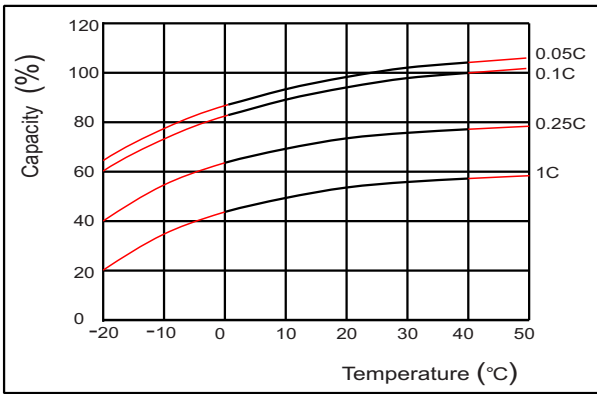

● Self-discharge characteristics

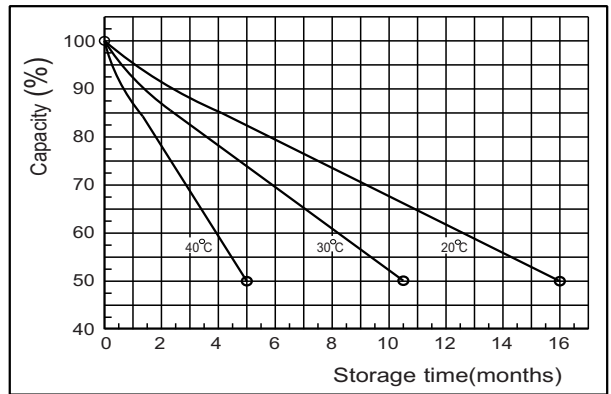

● Floating life on temperature

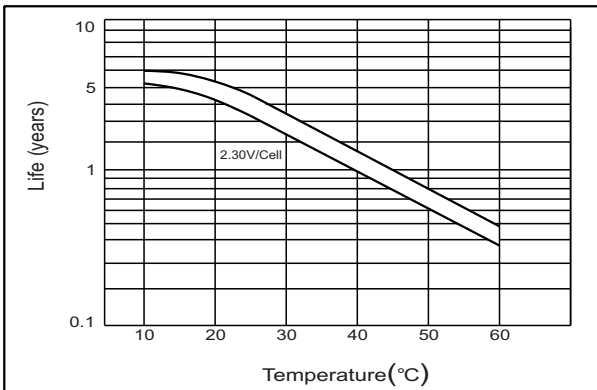

● Cycle life on D.O.D(25°C)

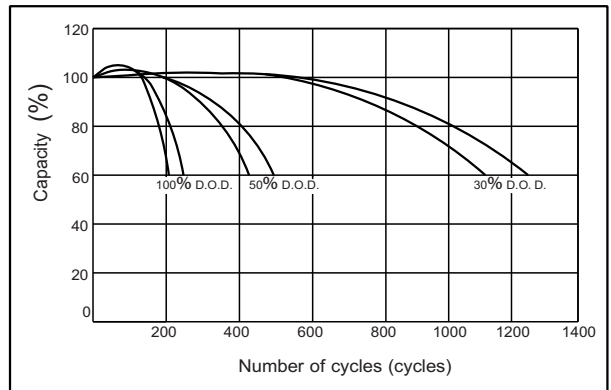

● The relationship for OCV and Capacity (25°C)

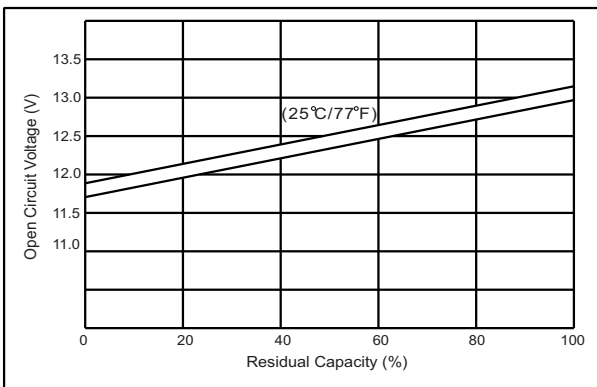

● The relationship for Charging voltage and Temperature

